

A300 DL



The mixer **A300 DL** is equipped with one arm with T-shaped paddles easily removable that ensures a comfortable and perfect cleaning. The **A300 DL** standard model is equipped with 1 mixing speed and two turning senses, although optionally the machine can be supplied with adjustable Variable Speed by means of a digital potentiometer which ensures an ideal mixing for different types of product.

The machine is equipped with a digital timer in which the total mixing time and partial times of each sense of rotation can be selected.

The unloading is done by means of push-buttons through a manual opening flap. The unloading area is designed for the positioning of a 200 litres bin at the exit of the product and strictly complies with all current safety regulations.

The **A300 DL** mixers can be equipped with a column lifter for 200 litres bins fixed to the machine and fitted with a tray to prevent the product from falling during loading.



CHARACTERISTICS

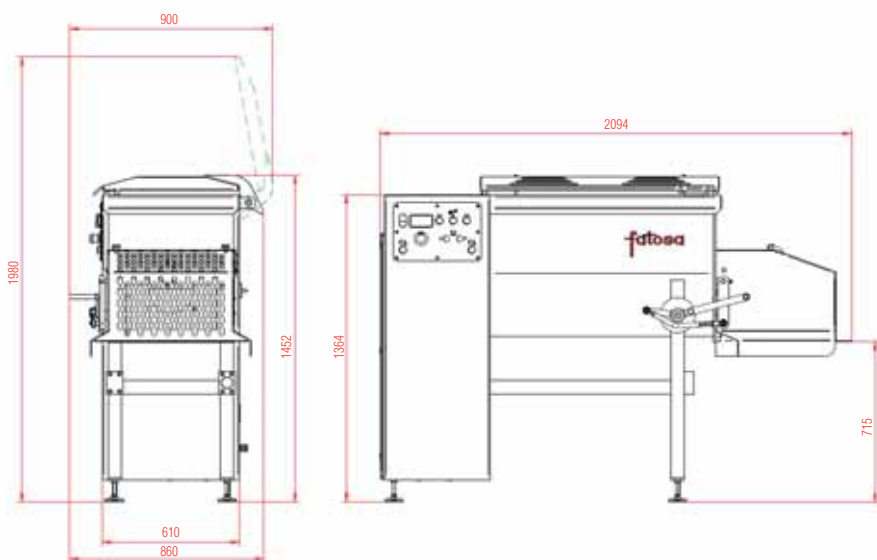

A300 DL

Capacity	200 Kgs
Total power	3 kw
Optional	Digital timer Variable speed Lifter EC250

fatossa

Telf. 1: +34 937 266 399
 Telf. 2: +34 937 266 889
 Fax. : +34 937 274 046
 Mail: info@fatossa.com

Ctra. de Terrassa, 217
 08205 Sabadell (Barcelona)
 España
www.fatossa.com